

**Modern
Rotary
For
Busy People**

Becton & District
Rotary
Club



**www.
bectonrotary
.org.uk**

<https://www.facebook.com/bectonrotary>

The Becton Bag

Thank you for your interest in making The Becton Bag.

Becton Rotary has embarked on this project to reduce the number of plastic carrier bags used for deliveries by New Forest Basics Bank. By making these bags we are supporting our New Forest Basics Bank and helping the environment.

The following pages contain the Pattern Instructions and Illustrations to support you in making The Becton Bag.

These bags need to be strong enough to hold canned goods and other foodstuffs, and this is why we are recommending the use of particular materials.

To ensure the bags are fit for purpose, they have been designed in conjunction with the New Forest Basics Bank based on their experience over thousands of deliveries and it is therefore important that these measurements are followed as closely as possible.

We realise you will be using recycled material and this may make this difficult, but if you could adhere as near to the dimensions as possible, this will improve the bags' functionality.

The Becton Bag Label may be sewn anywhere on the front of the bag.

You can collect material and labels, and deposit finished bags, at a number of collection/drop-off points throughout the area including New Milton, Milford on Sea, Barton on Sea, Sway and the New Forest Basics Bank in Lymington. Please message or email us for the address of your nearest collection/drop-off point.

By making The Becton Bag, you are supporting New Forest Basics Bank and making our environment a cleaner and safer place for us all to live in.

If you have any queries regarding the making of the bag, please contact us at:

bectonbag@bectonrotary.org.uk Facebook - <https://www.facebook.com/bectonrotary>

For general enquiries concerning Becton & District Rotary Club please contact Club Secretary Larry Anthony E-mail secretary@bectonrotary.org.uk

Many thanks

Keith

Keith Williams
President Becton Rotary

Rotary Club of Becton & District Trust Fund No. - 100285



The Becton Bag

Pattern Instructions

Recommended materials: Strong cotton, calico, cotton tablecloths, curtaining (not too thick), furnishing material (not too thick) or similar. The materials can be of any colour or pattern, but should be pre-washed to avoid shrinkage.

Amount of material required: 1m x 0.90m (40" x 36"). Handles - **Fig 1 b)** can be made in a different material.

Fig 1 a) - Top Hem

Turn top edge of material over by 10mm / ½" (approx.) **twice**. Press and stitch.

Fig 2 a) - Handles H1 and H2

Make 1cm / ½" fold on **short** edges with wrong side of fabric facing, and press.
Make 3cm / 1" folds on **long** edges with wrong side of fabric facing.

Fig 2 b)

Fold handle in half lengthways by bringing folded sides together, with raw edges meeting in centre and enclosed. *Optionally*, add wadding or heavyweight interfacing between the folds. Press and stitch all four sides close to edges.

Fig 2 c) - Attach handles

Pin and stitch handles to right side of bag fabric spacing as per measurements given in illustration. Add reinforcing stitching at top and bottom of handles as shown. Note: Handle loops omitted from illustration for clarity.

Fig 2 c) - Attach label

Place one label anywhere on the front of bag. Sew all four sides.
Fold material in half along fold line C with right sides together.

Fig 3 a) - Side and Bottom seams

Stitch side seam 1-1 **twice** for extra strength, using a 15mm / 5/8" seam allowance. Repeat for bottom seam 2-2. Overlock/serge (optional).

Fig 3 b) - Gusset

Keep bag inside out and fold so that side seam 1-1 is centred as shown. Pin in place.
Measure approx 16cms / 6½" to create sewing line 3-3 on pattern. Sew this line **twice** for extra strength. Repeat for other corner. Leave corners uncut for extra strength.

End

100cm / 40"



Fold 1cm / 1/2" (approx.) **twice** to form top hem

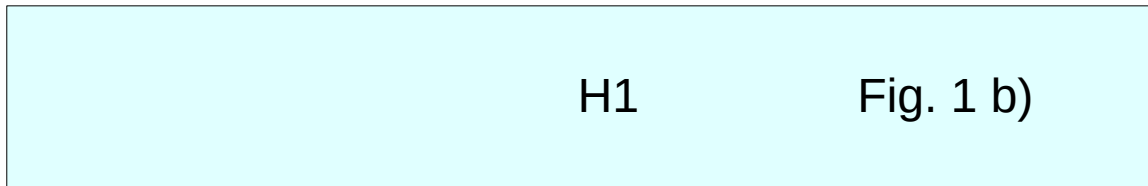

Fig. 1

Fig. 1 a)

56cm / 22"

76cm / 30"



H1

Fig. 1 b)

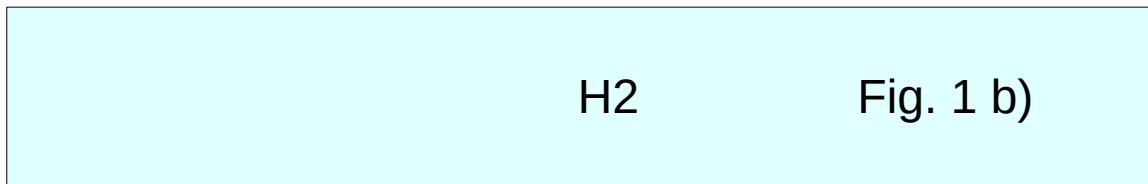

H2

Fig. 1 b)

12cm / 4 1/2"

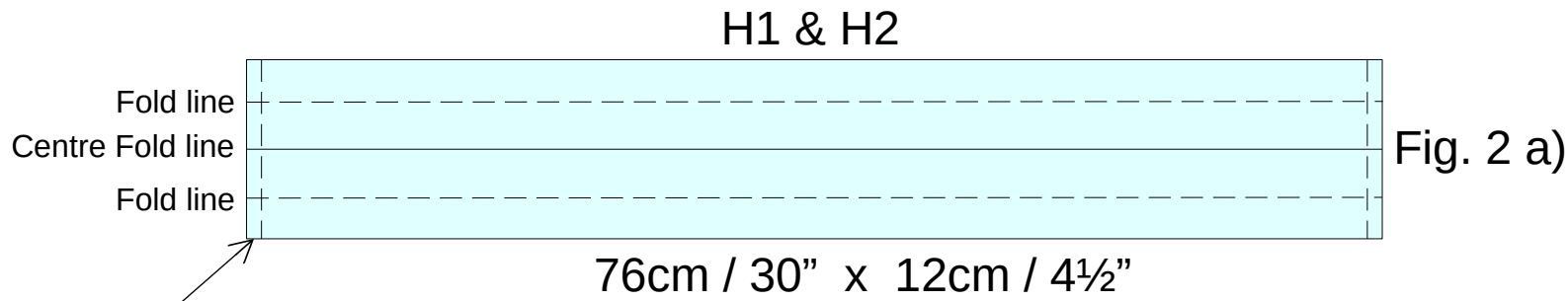

1cm / ½"

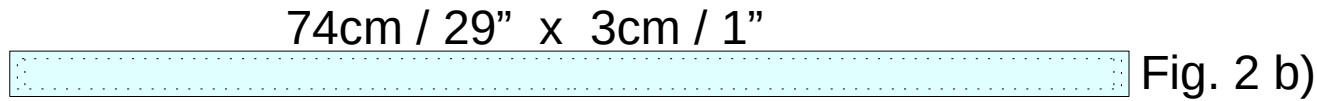

Fig. 2

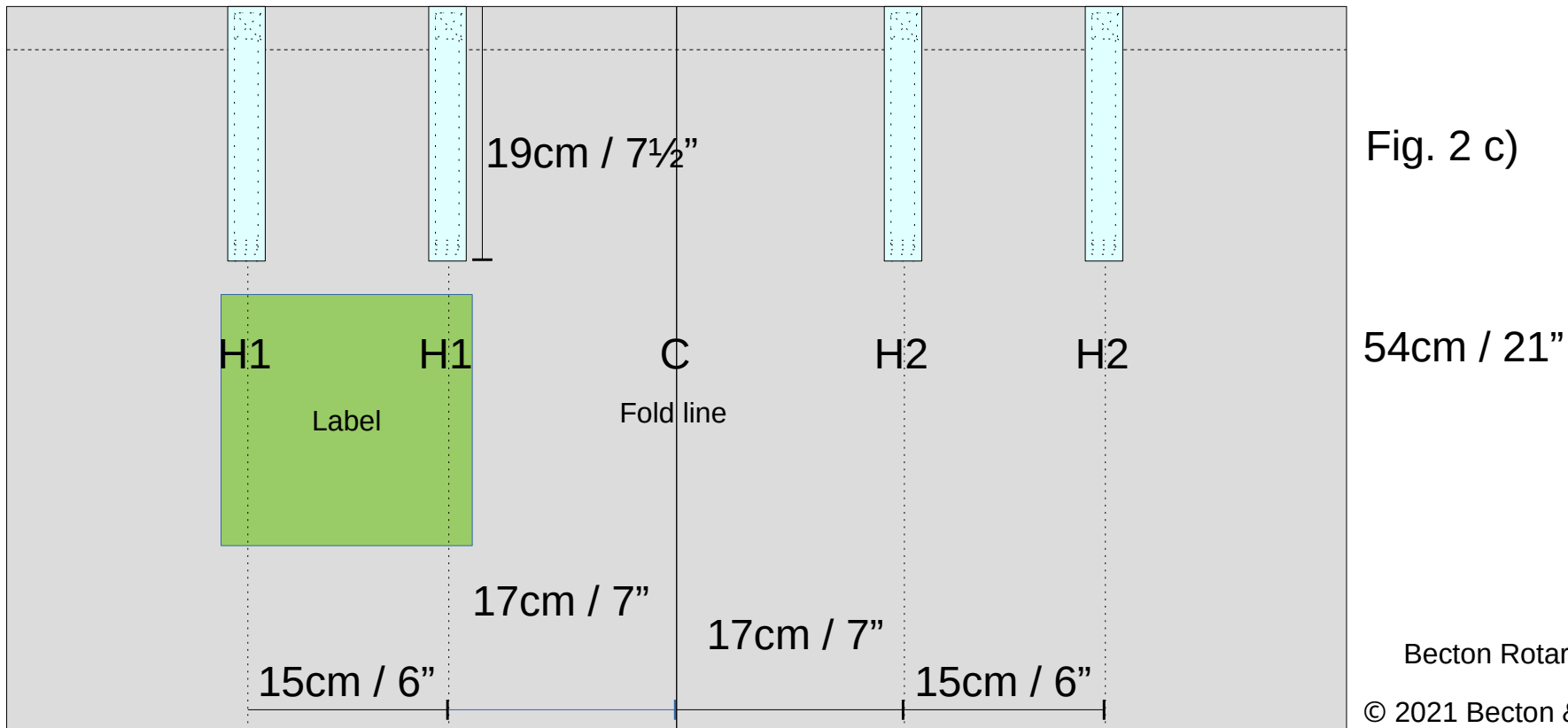



Fig. 3

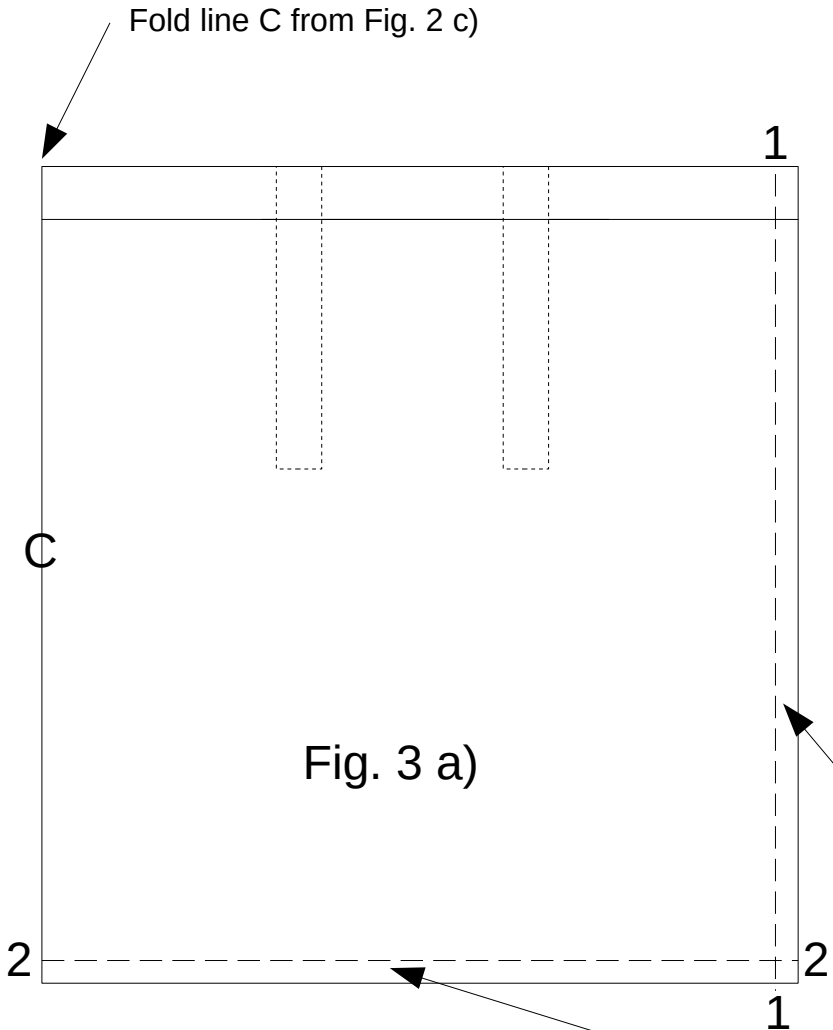

Fig. 3 a)

15mm / 5/8"

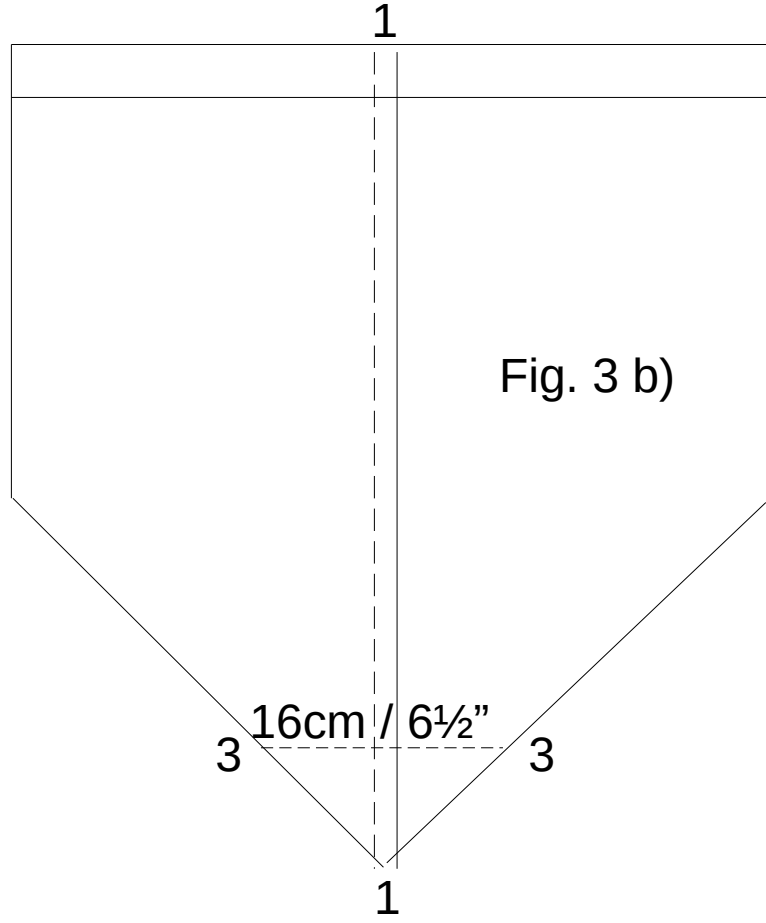

Fig. 3 b)